

Condensate Drainage System

Whenever the surface temperature of a building element drops below the dew point for the ambient surroundings there is a potential for surface condensation of water vapor. Skylight structures are no exception to this rule, and in the past have been particularly vulnerable to condensation because of their relatively low insulating value.

With the use of high performance insulating glass units and thermally broken framework the interior surface of the skylight unit is maintained at a higher temperature which reduces the range of possible dew point temperatures and thus the potential for condensation. No system however can completely eliminate the possibility of water condensation.

For this reason all Wisconsin Solar Design structures are provided with an integral condensate collection system which functions to collect any accumulated water and direct it to the exterior of the building. The operation of this system is described in the sill detail below.

In the event of condensation of water vapor at the inner surface (room side) of skylight glazing the accumulated water will flow to the bottom edge of the glazing unit. This water is accumulated in the condensate gutter in the rafter or purlin bar where it is channeled to the perimeter condensate gutter located in the sill bar. Water in the sill bar is then drained to the exterior of the skylight through a series of weep holes.

The sill flashing forms a trough with the sill bar to collect any overflow from the sill gutter. This flashing provides a secondary drainage system at the inner side of the perimeter sill bar. Water accumulated in this flashing trough flows by gravity below the sill bar through weep holes to the building exterior.

It is worth noting that although we describe condensate in terms of "accumulation" and "flow", the actual volume of condensate that can form under typical room conditions is generally quite low. In the event of special ambient room conditions which maintain constant high humidity such as above a waterfall fountain, special provisions may be taken to further control condensate formation and removal.

WISCONSIN SOLAR DESIGN

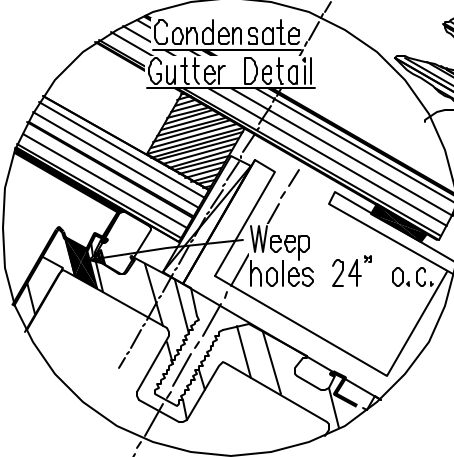
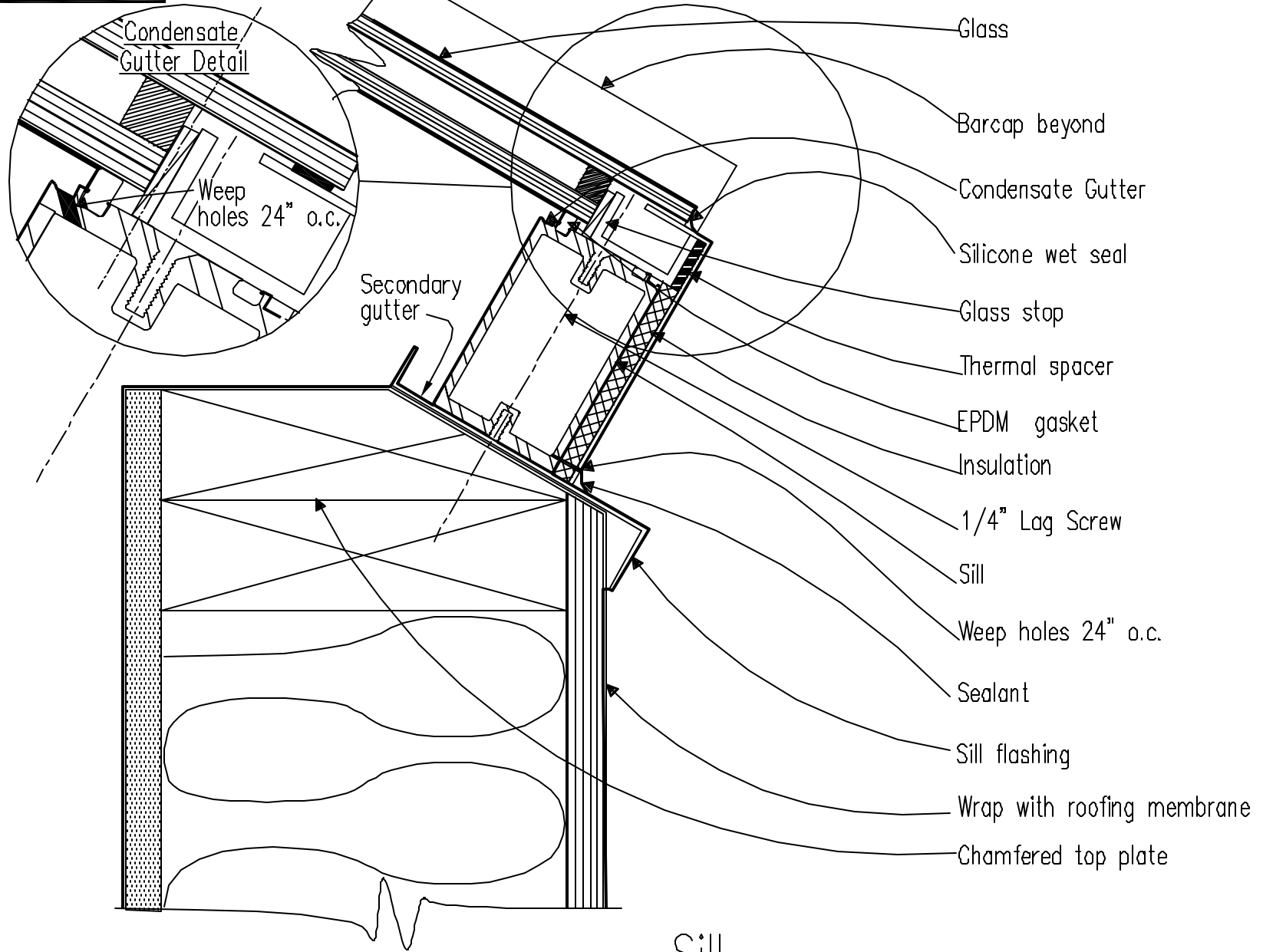

Sill

half scale